



Thank you for your interest in SmartMove Modular Conveyors. Requested literature detailing SmartMove gate conveyors is provided for your immediate review.

SmartMove Conveyors has been providing simple, safe, dependable conveyor solutions for more than 15 years. We offer a wide selection of product that are in stock and ready for immediate delivery. All of our conveyors provide the following benefits:

Save on installation: All SmartMove conveyors are shipped fully assembled and will be ready for operation upon delivery. There are no hidden costs for mechanical or electrical installation. And our removable power cord meets OSHA requirements for power lock-out.

Provide a safe work environment: No other conveyor can offer you the inherent safety provided with safer small torque motors. All of our drives have overload protection that shuts off the motor if stalled for more than 10 seconds. Plus, our belting provides a second safety defense by snapping open when jammed from underneath. Safe conveyors can improve your productivity by allowing workers to operate closer to the conveyor.

Modular and efficient: Modularly constructed to meet current and future needs at your facility. Save on operational electrical costs with our energy efficient variable speed brushless drives that use 80% less power than other conveyors. The information pack includes the following:

- [Conveyor Worksheet](#)
- [Detailed Product Description](#)
- [CAD Drawing](#)
- [Gate Photo](#)

If you have any questions regarding any SmartMove Conveyor product, I can be reached directly at (800) 581-2876 or by email at sales@4smartmove.com.

Regards,

Paula Wright
SmartMove Conveyors
Phone: (800) 581-2876
Fax: (508) 679-5202
Email: sales@4smartmove.com

Pricing, Videos, Cad Drawings, Accessories and More...

www.4smartmove.com

AMAENGINEERING *Smartmove Conveyors*

683 American Legion Highway, Westport, MA 02790

Phone: 800-581-2876 Fax 508-679-5202 Email: Sales@4smartmove.com





SmartMove Short Line Quote Request Worksheet

Thank you for your interest in gaining a quote from SmartMove Conveyors. Please note that the more complete the information that you provide us, the better we can serve you. The data you supply is also critical to correctly process your quote.

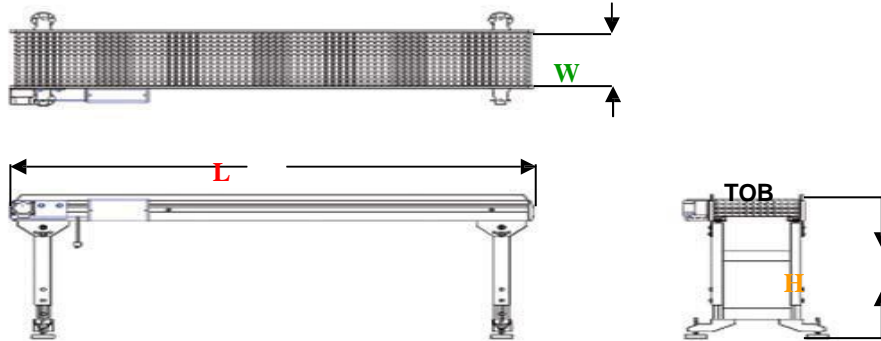

CALL SALES @ (800) 581-2876 FOR ASSISTANCE.

	Select from:	Choose Here	Notes															
Belt Width:	<table border="1"> <tr> <td>6"</td> <td>9"</td> <td>12</td> <td>15</td> <td>18</td> </tr> <tr> <td>21</td> <td>24"</td> <td>27"</td> <td>30</td> <td>33</td> </tr> <tr> <td>36</td> <td>39</td> <td>42</td> <td>45</td> <td>48</td> </tr> </table>	6"	9"	12	15	18	21	24"	27"	30	33	36	39	42	45	48		Conveyor is 1" wider than the belt width
6"	9"	12	15	18														
21	24"	27"	30	33														
36	39	42	45	48														
Conveyor Length:	<p>24-120"</p> <p>See Worksheet</p>		Worksheet needed for Long Lines longer than 120"															
Height	<table border="1"> <tr> <td>9"-13"</td> <td>13"-17"</td> <td>16"-20"</td> <td>22"-27"</td> </tr> <tr> <td>25"-33"</td> <td>28"-39"</td> <td>34"-48"</td> <td>40"-60"</td> </tr> <tr> <td>55-75</td> <td>72-112</td> <td></td> <td></td> </tr> </table>	9"-13"	13"-17"	16"-20"	22"-27"	25"-33"	28"-39"	34"-48"	40"-60"	55-75	72-112				Height is measured from base of support stand to the top of the belt (TOB). Stands can be shared between joined conveyors			
9"-13"	13"-17"	16"-20"	22"-27"															
25"-33"	28"-39"	34"-48"	40"-60"															
55-75	72-112																	
Belt Speed	<table border="1"> <tr> <td>2-25</td> <td>3-50</td> <td>4-70</td> </tr> <tr> <td>6-100</td> <td>7-138</td> <td>12-208</td> </tr> </table>	2-25	3-50	4-70	6-100	7-138	12-208		Comes with our patented direct drive 25-90 watt brushless DC 115V plug and play all ball bearing motors.									
2-25	3-50	4-70																
6-100	7-138	12-208																

What are you using the conveyor for?
 Your Company name and physical address:
 Contact name:
 Direct line:

Pricing, Videos, Cad Drawings, Accessories and More...

www.4smartmove.com

AMAENGINEERING *Smartmove Conveyors*
 683 American Legion Highway, Westport, MA 02790
 Phone: 800-581-2876 Fax 508-679-5202 Email: Sales@4smartmove.com





SmartMove Walk-Thru Gate Conveyor Crossings

Conveyor layout design has never been easier with SmartMove's Walk-Thru Gate systems. Including a conveyor crossing in your layout will allow you to make continuous loops, gain access to otherwise blocked pathways and provide the opportunity to go where you need to go with the conveyors.

To request a quotation on a SmartMove Walk-thru Gate system, please complete this form and send it along with a completed Short Line or Long Line worksheet.

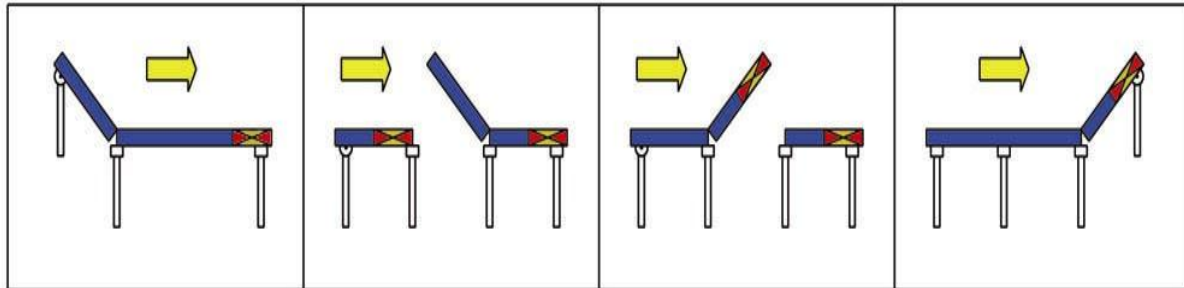

**Idler Gate crossing requires preceding conveyor to be installed with gate sensor shut-off switch.*

Location	<i>(We recommend the Drive Gate crossing that shuts off feed while gate is open.)</i>
Walk-thru Clearance	Gate section will be 2" longer, 5" longer if using Folding Stand Option. <i>We recommend 36" long gate to a 34" walk-thru clearance. If you need a larger crossing width, please consider a dual system that uses a Drive at end gate combined with an Idler Gate crossing system to provide clearance up to 90"</i>
Ceiling Clearance	Ceiling clearance is required for gate open position <i>Gate length + Overall Conveyor Height = Clearance</i>
Product Length	Products under 3" will need back-pressure to cross joint at gate. <i>Gate can waterfall transfer for smaller products.</i>

Please include this information with the Short Line or Long Line worksheet

Pricing, Videos, Cad Drawings, Accessories and More...

www.4smartmove.com

AMAENGINEERING *Smartmove Conveyors*

683 American Legion Highway, Westport, MA 02790

Phone: 800-581-2876 Fax 508-679-5202 Email: Sales@4smartmove.com





SmartMove Conveyor with walk-thru-gate

30" - 48" long (ordered when purchasing a Short Line Conveyor)

Standard dimensions are shown here for reference.

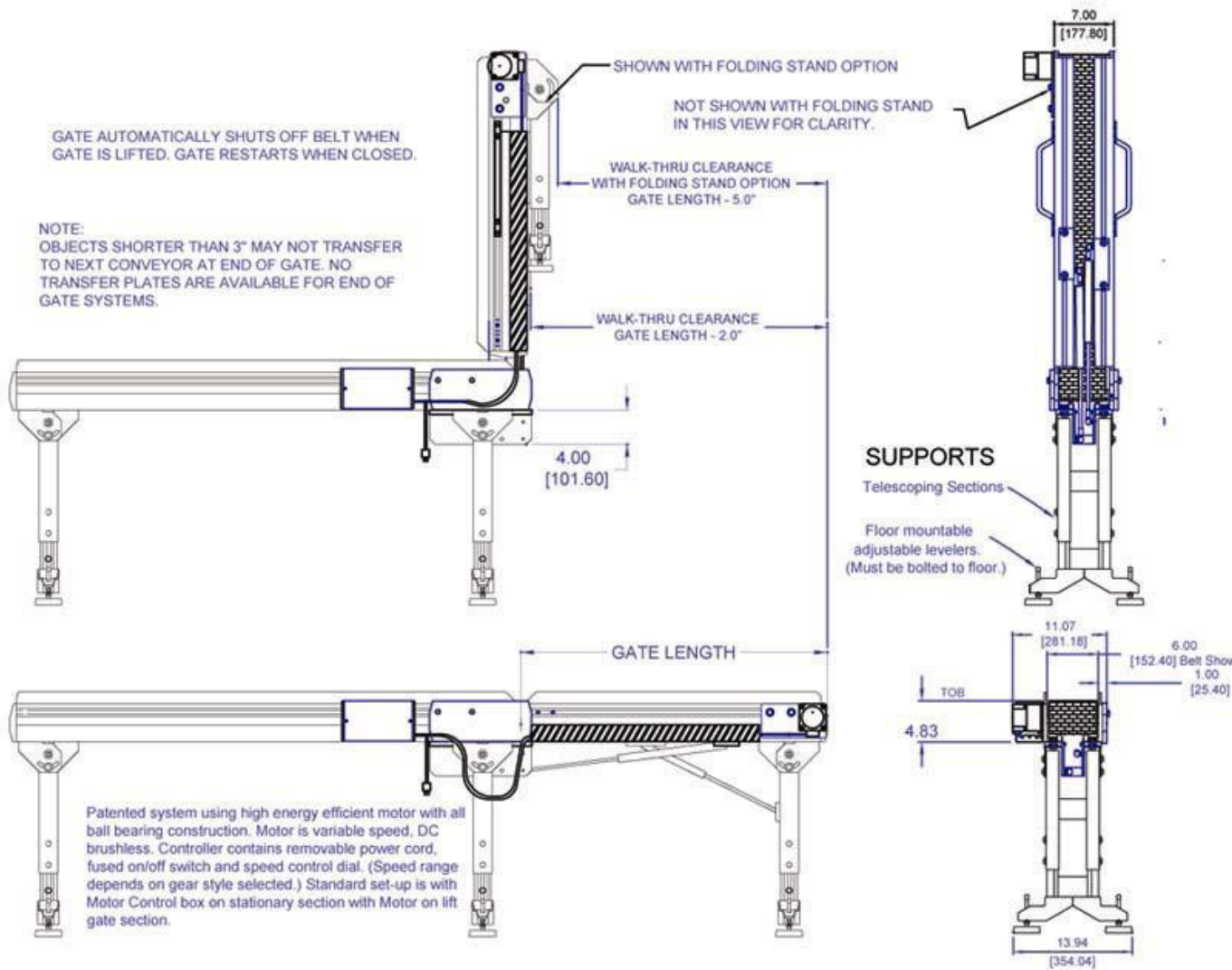

Available in width from 6" to 30"

[Pricing, videos, cad drawings, accessories, manuals and more....](#)

Pricing, Videos, Cad Drawings, Accessories and More...

www.4smartmove.com

AMAENGINEERING *Smartmove Conveyors*
 683 American Legion Highway, Westport, MA 02790
 Phone: 800-581-2876 Fax 508-679-5202 Email: Sales@4smartmove.com





Pricing, Videos, Cad Drawings, Accessories and More...

www.4smartmove.com

AMAENGINEERING *Smartmove Conveyors*
683 American Legion Highway, Westport, MA 02790
Phone: 800-581-2876 Fax 508-679-5202 Email: Sales@4smartmove.com



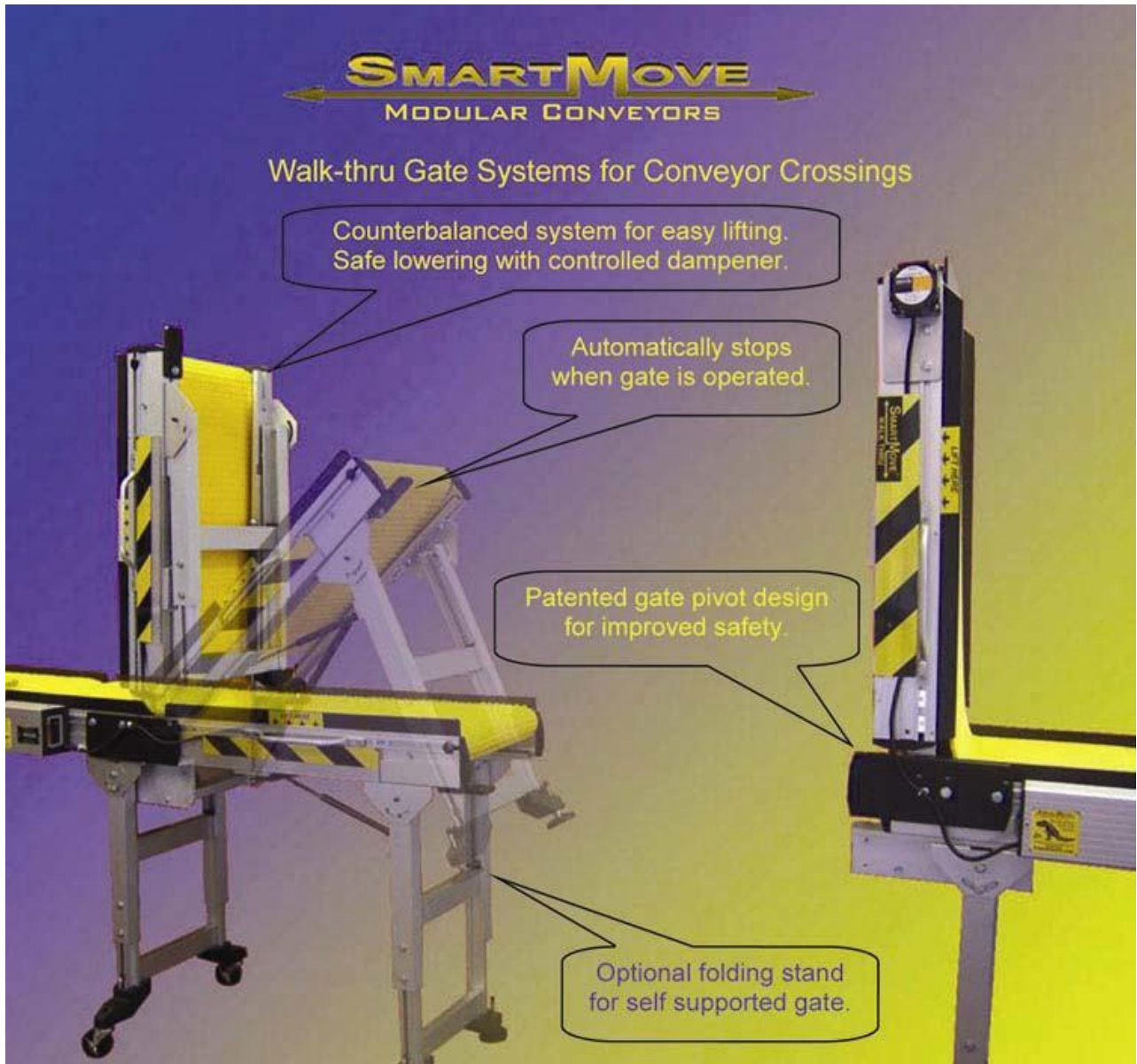

Pricing, Videos, Cad Drawings, Accessories and More...

www.4smartmove.com

AMAENGINEERING *Smartmove Conveyors*
683 American Legion Highway, Westport, MA 02790
Phone: 800-581-2876 Fax 508-679-5202 Email: Sales@4smartmove.com

