

End-to-Side Transfer Plate and Corner Turn Plate

Product Description

Transferring products around 90° turns is accomplished by placing the end of one conveyor flush to the side of another conveyor. By removing the guard rail at the juncture of the two conveyors and replacing it with an End-to-Side Transfer Plate, it will then be possible to push and pull the products around a corner with a sliding motion. SmartMove®'s unique End-to-Side Transfer Plates are designed to support products above the belt during transfer and then tilt to a lower position as the product slides around the turn. Unlike tensioned belt systems, the force caused by the side transfer will not affect the belt tracking.

End-to-side Transfer Plate for flat belt

The transfer plate allows the products to slide across the joint without catching the edge of the belting. Most products with flat bottoms can make 90° turns. However, products less than 3" long will "stall" at the transfer plate. (Hence, the common name for these plates is "Dead Plate".) Stalled items will require a push from items traveling behind, (this is considered "back-pressure") to proceed forward. With a continual flow of material, you can get satisfactory results by using back pressure to transfer short items across transitions. As products make the turn, they will normally rotate as shown in the figure below.

Corner Turn Plate

Installing a Corner Turn Plate will help keep products from catching the edges of the 1" high guard rail as they turn. Although 90° turns will work with most products, there are some limitations that you should be aware of before purchasing systems requiring turns. Our on-line calculator can be used to determine the correct width conveyor based on your product size. Please send samples if you would like us to test your product.

Other limitations

Transfer plates are available for flat and brush belting. Transfer plates cannot be used with belting that has ribs or attachments to the belt surface as they may catch when traveling under the transfer plate.

Too small for turns? Please consider "waterfall transfer" if your product is too small for turns.

For other transfers, please see End-to-End Transfer Plates and End-of-Line Transfer Plates.

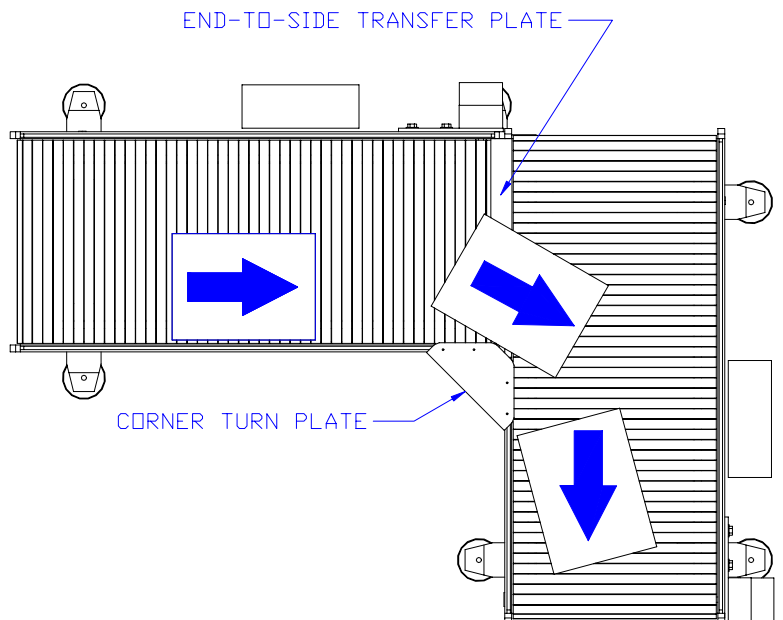

Phone:800-581-2876 Fax: 508-679-5204 e-mail:sales@4smartmove.com

Please visit our website at www.4smartmove.com for pricing, videos, cad drawings, accessories, manuals and more...

PLEASE SAVE WITH OWNERS MANUAL