

683 AMERICAN LEGION HWY WESTPORT, MA 02790 PHONE: 800-581-2876 FAX: 508-679-5204 E-MAIL: SALES@4SMARTMOVE.COM

All new **Hump-back** conveyor is designed to handle hot circuit boards exiting from wave solder machines. Belt is static dissipative and available with full surface ribs for increased cooling. We do custom angles and elevations to meet your requirements for "drop-in" replacement of existing systems. Designed for maintenance free performance.



**Product Description:** 115 Volt AC motor driven chain belt conveyor with 3/8" high vertical flights on 3/4" centers. Variable speed control to match your exit speed. Static dissipative belting is custom molded by SmartMove<sup>®</sup> with "snap-together" features and proprietary self-lubricating additives that virtually eliminates belt wear and maintenance. Safe, clean and simple!

For accumulating boards, simply add another conveyor with our BS (brush) belting with an adjustable end stop. The bristles will not harm the undersides of boards.

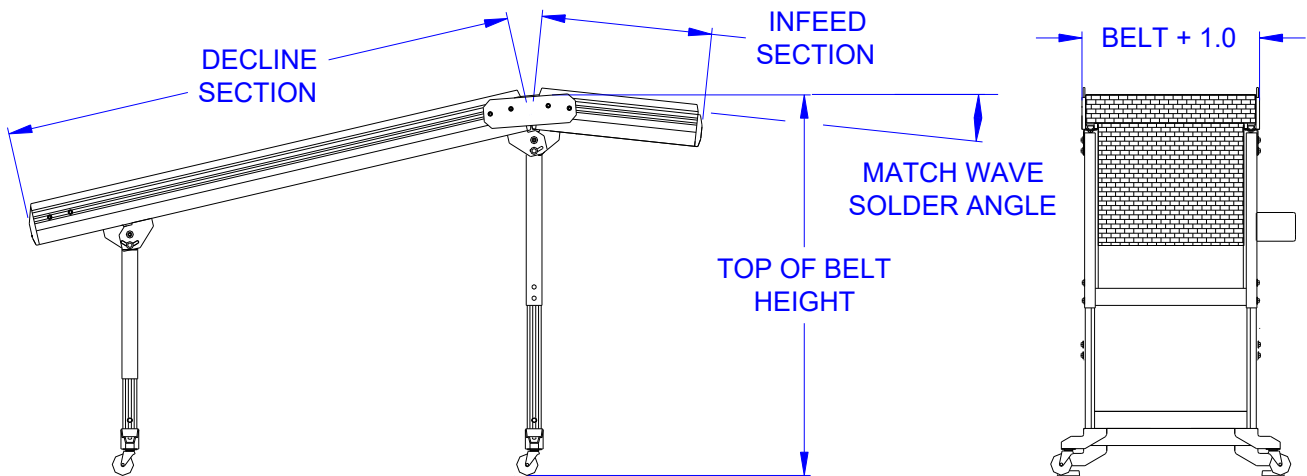

Please call, fax or e-mail your requirements and we will promptly respond with pricing and delivery. We specialize in customs with short lead times. (2-3 weeks ARO)

**ENERGY SAVING**  
Uses **90%**  
LESS POWER



PROUDLY MADE IN USA